

Integrated Single DishDrawer™ Dishwasher, Tall

Series 9 | Integrated

Panel Ready



Integrating into your kitchen design seamlessly, with extra height for larger dishes in the tall top drawer.

- With extra height for taller dishes, and customisable internal shelving
- Knock to pause function is perfect if you miss a dish
- Quick wash, Sanitise and Extra Dry options provide superior performance
- Customise with your own front panel and handle to match your kitchen cabinetry, or choose our stainless steel panel

DIMENSIONS

Height	454mm
Width	599mm
Depth	571mm

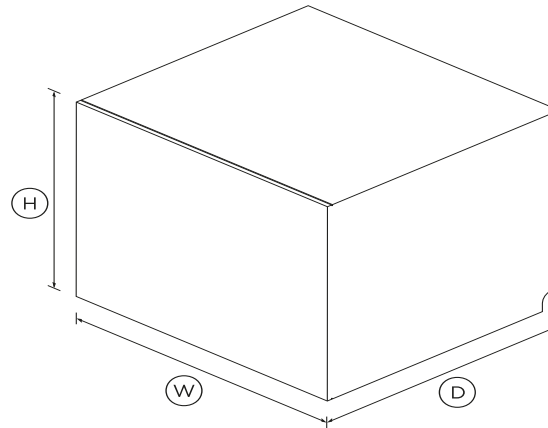

FEATURES & BENEFITS

Seamless integration

Slide your DishDrawer™ Dishwasher into an existing kitchen space or integrate into kitchen cabinetry, for a seamless look whilst delivering superior dish care.

Ease of use

DishDrawer™ Dishwashers are as easy to open and close as kitchen drawers and can be conveniently positioned at bench height for ease of loading and minimal bending. Flexible racking allows you to make adjustments to fit in a variety of dishes.

Quick, Sanitise and Extra Dry options

The Quick wash modifier delivers a faster wash while maintaining performance. The Sanitise option provides extra protection killing 99.9% of bacteria in the final rinse. The Extra Dry setting is perfect for plastic dishes.

Knock to pause

These DishDrawer™ Dishwashers have a knock to pause function. A knock on the front panel will pause the dishwasher which can be re-started again by using the start/play button.

Quiet performer

Running at a very low decibel rate, these DishDrawer™ Dishwashers do their job without making a fuss. The combination of intelligent technology and simple mechanics means greater reliability and excellent wash performance.

SPECIFICATIONS

Accessories

- Cutlery basket
- Knife clip and multipurpose

Capacity and loading

Accommodates round plates	310mm
Adjustable height, foldable	•
Fold down tines	•
Pitch adjustable tines	•

Consumption

Energy rating	F
Water consumption per cycle	7.9L

Controls

- Child lock •
- Electronic fault/Diagnostic •
- End of cycle beeps •
- Energy saving delay start •
- Internal wash selector •
- Knock to pause •
- Rinse aid indicator light •

- Fast •
- Heavy •
- Quick •
- Rinse •
- Sanitize •

Water connection

Water pressure **0.1 Mpa - 1 Mpa**

SKU **81237**

The product dimensions and specifications in this page apply to the specific product and model. Under our policy of continuous improvement, these dimensions and specifications may change at any time. You should therefore check with Fisher & Paykel's Customer Care Centre to ensure this page correctly describes the model currently available. ? Fisher & Paykel Appliances Ltd 2020



A PEACE OF MIND SALE

24 Hours 7 Days a Week Customer Support

T 08000886605 Wwww.fisherpaykel.com

Features

- Built-in water softener •
- Fan assisted drying •
- Flow through detergent •
- Quiet operation •
- SmartDrive™ technology •

Performance

Noise on standard cycle top **43dBA**

Power requirements

Amperage **4.2A**

Product dimensions

Depth **571mm**

Height **454mm**

Width **599mm**

Wash Programs

- Delicate •
- Eco •
- Extra Dry •